

ShiftAir
Beyond the limits...



Product Catalogue

ShiftAir® – A TECHNOLOGY MULTI FOLD AHEAD OF CONVENTIONAL INDUSTRIAL PIPING SYSTEM

ShiftAir Pneumatics based at Faridabad, Haryana has incorporated in 2015 with a mission & vision to be the leader in the field of modular piping system both in aluminium and stainless steel suitable for wide range of industrial fluids.

To overcome the common problems with conventional piping system like rusting, leakages & pressure drop ShiftAir® introduces all Aluminium Alloy pipes & fittings which is completely corrosion free. The inner surface of pipes are chromatised to make it smooth which in turn reduces the frictional losses and high surface contact integral seals ensure the leakproof system. Aluminium pipes coating materials (at external surface) are as per QUALICOAT standard. Light weight & modularity by design make the piping system very easy to install and design the layout as & when required.

ShiftAir® is the first ever Indian piping company to use all aluminium clamp type connection technology across all the sizes.

Applications:

Compressed Air, Inert Gases, Vacuum, Nitrogen, Carbon Dioxide etc. Customers are requested to consult with us for any other Industrial Fluids Like Water, Oil etc.

Technical Parameters:

Pipe Grade	: 6063–T5 (Seamless extruded pipes in accordance with EN755.2, EN573.3)
Grade of fittings material	: A 383 with SS bolts & gripping ring
Maximum working pressure	: 15 bar
Temperature range	: –20°C to 80°C
Vacuum	: 0.013 bar (Absolute Pressure)
Outer surface coating as per "QUALICOAT" standard	
Chromatised inner surface which reduces frictional losses	
Standard conformation	: CE, TUV, ISO 9000:2015, UL–94V.0, ROHS, ASTM E 1251–17a, IS1608

Aluminum alloy tube

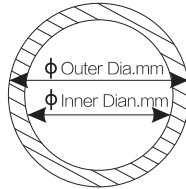

Aluminum alloy blue tube

Part Code	Nominal Diameter	Outer Diameter (mm)	Inner Diameter (mm)	Length (m)
AP 20 06 00	20	20.1	17.5	6.0
AP 20 03 00	20	20.1	17.5	3.0
AP 25 06 00	25	25.1	22.5	6.0
AP 25 03 00	25	25.1	22.5	3.0
AP 40 06 00	40	40.1	36.5	6.0
AP 40 03 00	40	40.1	36.5	3.0
AP 50 06 00	50	50.1	45.7	6.0
AP 50 03 00	50	50.1	45.7	3.0
AP 67 06 00	65	67.6	63	6.0
AP 67 03 00	65	67.6	63	3.0
AP 84 06 00	80	84.8	80	6.0
AP 84 03 00	80	84.8	80	3.0
AP A1 06 00	100	101.8	96.8	6.0
AP A1 03 00	100	101.8	96.8	3.0
AP A2 06 00	150	153	147.5	6.0
AP A2 03 00	150	153	147.5	3.0
AP A3 06 00	200	205	197.8	6.0
AP A3 03 00	200	205	197.8	3.0

Aluminum alloy grey tube

Part Code	Nominal Diameter	Outer Diameter (mm)	Inner Diameter (mm)	Length (m)
AP 20 06 01	20	20.1	17.5	6.0
AP 20 03 01	20	20.1	17.5	3.0
AP 25 06 01	25	25.1	22.5	6.0
AP 25 03 01	25	25.1	22.5	3.0
AP 40 06 01	40	40.1	36.5	6.0
AP 40 03 01	40	40.1	36.5	3.0
AP 50 06 01	50	50.1	45.7	6.0
AP 50 03 01	50	50.1	45.7	3.0
AP 67 06 01	65	67.6	63	6.0
AP 67 03 01	65	67.6	63	3.0
AP 84 06 01	80	84.8	80	6.0
AP 84 03 01	80	84.8	80	3.0
AP A1 06 01	100	101.8	96.8	6.0
AP A1 03 01	100	101.8	96.8	3.0
AP A2 06 01	150	153	147.5	6.0
AP A2 03 01	150	153	147.5	3.0
AP A3 06 01	200	205	197.8	6.0
AP A3 03 01	200	205	197.8	3.0



Equal Connector

Part Code	Nominal Diameter	L	A	B
EC 20 00 01	20	59	36	41
EC 25 00 01	25	59	42	44
EC 40 00 01	40	78	69	60
EC 50 00 01	50	79	80	74
EC 67 00 01	65	114	98	121
EC 84 00 01	80	114	115	137
EC A1 00 01	100	146	128	157
EC A2 00 01	150	146	188	224
EC A3 00 01	200	135	240	265



Equal Elbow 90°

Part Code	Nominal Diameter	L	Z1
EE 20 90 01	20	59	36
EE 25 90 01	25	59	42
EE 40 90 01	40	78	69
EE 50 90 01	50	79	80
EE 67 90 01	65	114	98
EE 84 90 01	80	114	115
EE A1 90 01	100	146	128
EE A2 90 01	150	146	188
EE A3 90 01	200	135	240



Equal Elbow 45°

Part Code	Nominal Diameter	L	Z1
EE 20 45 01	20	118	70
EE 25 45 01	25	119	71
EE 40 45 01	40	159	92
EE 50 45 01	50	162	95
EE 67 45 01	65	144	84
EE 84 45 01	80	145	85
EE A1 45 01	100	179	105
EE A2 45 01	150	215	126
EE A3 45 01	200	231	135

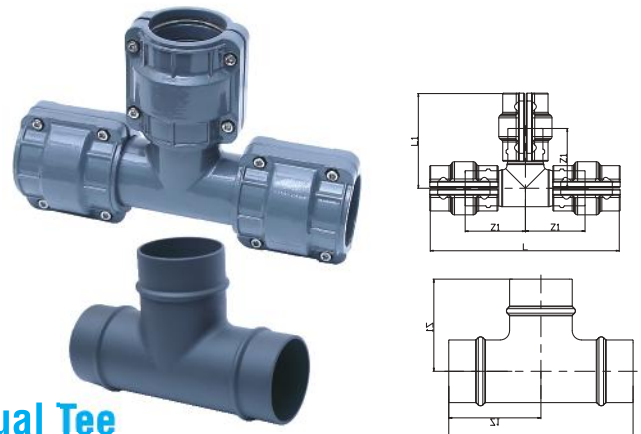

Equal Tee

Part Code	Nominal Diameter	L	L1	Z1
ET 20 00 01	20	160	80	100
ET 25 00 01	25	166	83	105
ET 40 00 01	40	218	109	139
ET 50 00 01	50	230	115	152
ET 67 00 01	65	200	100	137
ET 84 00 01	80	220	110	156
ET A1 00 01	100	262	131	186
ET A2 00 01	150	332	170	250
ET A3 00 01	200	375	187.5	293

Connectors

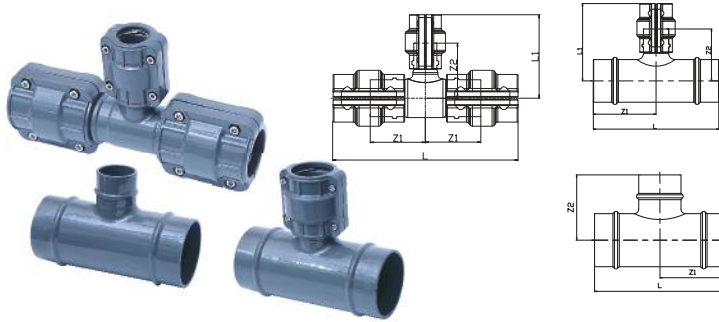

Reducing Tee

Part Code	Nominal Diameter	L	Z1	L1	Z2
RT 25 20 01	25 X 20	160	80	81	102
RT 40 25 01	40 X 25	200	100	90	120
RT 50 40 01	50 X 40	220	110	114	144
RT 67 40 01	65 X 40	200	100	122	159
RT 67 50 01	65 X 50	200	100	123	160
RT 84 40 01	80 X 40	190	95	132	178
RT 84 50 01	80 X 50	200	100	133	179
RT 84 67 01	80 X 65	210	105	105	151
RT A1 50 01	100 X 50	226	113	141	198
RT A1 67 01	100 X 65	236	118	118	172
RT A1 84 01	100 X 80	246	123	121	175
RT A2 67 01	150 X 65	242	121	150	230
RT A2 84 01	150 X 80	226	131	147	227
RT A2 A1 01	150 X 100	272	136	162	242
RT A3 67 01	200 X 65	240	120	170	276
RT A3 84 01	200 X 80	256	128	171	276
RT A3 A1 01	200 X 100	276	138	182	288
RT A3 A2 01	200 X 150	344	172	182	288

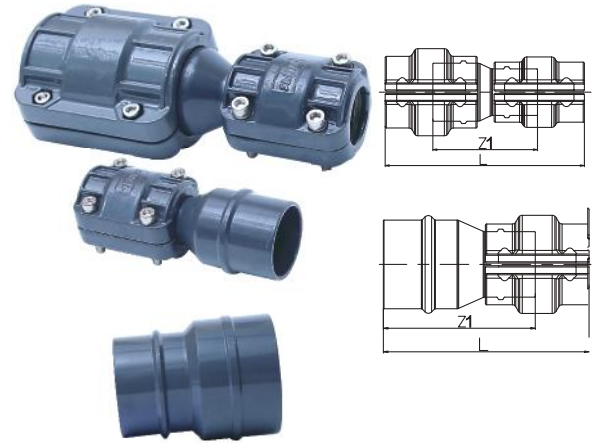

Unequal Connector

Part Code	Nominal Diameter	L	Z1
UC 25 20 01	25 X 20	130	66
UC 40 25 01	40 X 25	156	83
UC 50 25 01	50 X 25	160	85
UC 50 40 01	50 X 40	172	90
UC 67 40 01	63 X 40	156	115
UC 67 50 01	63 X 50	157	116
UC 84 50 01	80 X 50	158	116
UC 84 67 01	80 X 65	126	126
UC A1 67 01	100 X 65	152	152
UC A1 84 01	100 X 80	141	141
UC A2 84 01	150 X 80	150	150
UC A2 A1 01	150 X 100	155	155
UC A3 A2 01	200 X 150	170	170

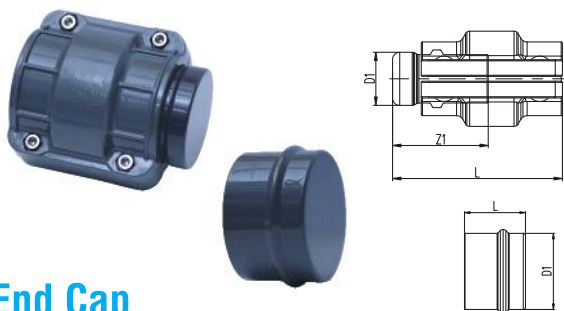

End Cap

Part Code	Nominal Diameter	L	D1
EP 20 00 01	20	70	22
EP 25 00 01	25	70	27
EP 40 00 01	40	90	42
EP 50 00 01	50	91	52
EP 67 00 01	65	54	68
EP 84 00 01	80	55	85.8
EP A1 00 01	100	70	101.8
EP A2 00 01	150	70	153
EP A3 00 01	200	70	205



Male Threaded Elbow 90°

Part Code	Nominal Diameter	L	L1	L2	Thread (BSP)
ME 20 21 01	20	95	79	49	1/2"
ME 20 27 01	20	95	79	49	3/4"
ME 25 21 01	25	102	82	52	1/2"
ME 25 34 01	25	102	82	52	1"
ME 40 49 01	40	141	109	69	1-1/2"
ME 50 48 01	50	150	114	74	2"

Male Socket

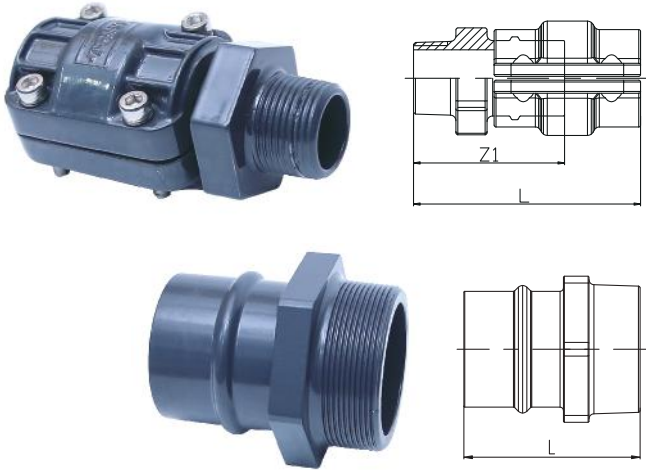

Part Code	Nominal Diameter	L	Thread (BSP)
MS 20 21 01	20	90	1/2"
MS 20 27 01	20	91	3/4"
MS 25 21 01	25	92	1/2"
MS 25 27 01	25	93	3/4"
MS 25 34 01	25	93	1"
MS 40 34 01	40	119	1"
MS 40 42 01	40	122	1-1/4"
MS 40 49 01	40	122	1-1/2"
MS 50 49 01	50	122	1-1/2"
MS 50 48 01	50	126	2"
MS 67 48 01	65	98	2"
MS 67 47 01	65	103	2-1/2"
MS 84 47 01	80	107	2-1/2"
MS 84 46 01	80	110	3"

Hose



Flexible Hose

Part Code	Nominal Diameter	Length (mm)	Description	Remarks
FH 20 05 SS	20	500	Stainless Steel Hose	Supplied with end connectors
FH 25 05 SS	25	500	Stainless Steel Hose	Supplied with end connectors
FH 40 05 SS	40	500	Stainless Steel Hose	Supplied with end connectors
FH 40 10 SS	40	1000	Stainless Steel Hose	Supplied with end connectors
FH 50 10 SS	50	1000	Stainless Steel Hose	Supplied with end connectors
FH 67 10 RB	65	1000	Flexible Rubber Hose	Connectors at both ends required
FH 84 10 RB	80	1000	Flexible Rubber Hose	Connectors at both ends required
FH A1 10 RB	100	1000	Flexible Rubber Hose	Connectors at both ends required
FH A2 14 SS	150	1400	Stainless Steel Hose	Connectors at both ends required
FH A3 14 SS	200	1400	Stainless Steel Hose	Connectors at both ends required

Quick Assembly Bracket

Features

- A new generation of quick adapter is recommended for vertical or horizontal tapping points
- It makes sure that condensed water if any won't flow down to the point of consumption, hence comparatively dry air
- Protruded part of the bracket automatically rest inside the hole of the tube, avoid human error while installing
- Quick installation does not require to cut the tubes.

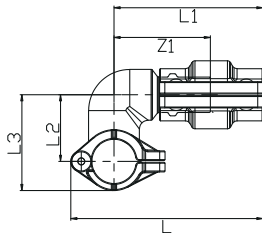

Quick Assembly 'U' Bracket

Part Code	Nominal Diameter	L	L1	L2	L3
QA 25 20 01	25 X 20	110	85	38	55
QA 40 20 01	40 X 20	125	91	45	70
QA 40 25 01	40 X 25	125	91	45	70
QA 50 20 01	50 X 20	129	89	54	84
QA 50 25 01	50 X 25	129	89	54	84
QA 67 20 01	65 X 20	152	89	71	112
QA 67 25 01	65 X 25	152	89	71	112
QA 84 20 01	80 X 20	158	89	77	127
QA 84 25 01	80 X 25	158	89	77	127
QA A1 20 01	100 X 20	154	83	97	154
QA A1 25 01	100 X 25	154	83	97	154
QA A2 20 01	150 X 20	202	82	123	204
QA A2 25 01	150 X 25	202	82	123	204
QA A3 25 01	200 X 25	256	84	149	267

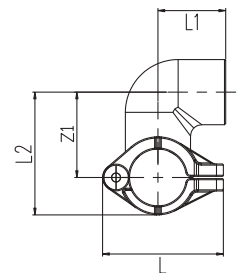
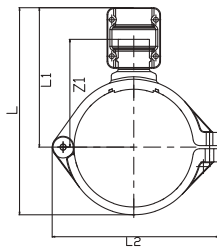

Quick Assembly Straight Bracket

Part Code	Nominal Diameter	L	L1	L2
QA A1 40 01	100 X 40	204	134	162
QA A2 40 01	150 X 40	267	180	215
QA A2 50 01	150 X 50	255	181	215
QA A3 40 01	200 X 40	329	206	269
QA A3 50 01	200 X 50	330	207	269

Female Threaded Bracket

Part Code	Nominal Diameter	L	L1	L2	Thread (BSP)
TD 25 21 01	25 X ½"	54	30	38	55
TD 40 21 01	40 X ½"	72	42	45	70
TD 50 21 01	50 X ½"	83	46	54	84
TD 67 21 01	65 X ½"	126	65	74	112
TD 84 21 01	80 X ½"	138	65	89	127
TD A1 21 01	100 X ½"	170	54	135	150
TD A2 21 01	150 X ½"	219	55	168	201

The Valve



Quick Push-in Ball Valve

Part Code	D1	D2	L
QV 20 00 01	20	20	165
QV 25 00 01	25	25	169
QV 40 00 01	40	40	232
QV 50 00 01	50	50	242

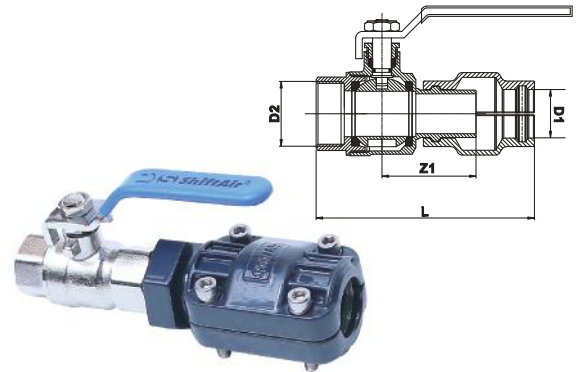

Single Port Female Ball Valve

Part Code	D1	D2	L
SV 20 21 01	20	½"	118
SV 25 21 01	25	½"	115
SV 25 34 01	25	1"	115
SV 40 49 01	40	1-½"	154
SV 50 48 01	50	2"	165

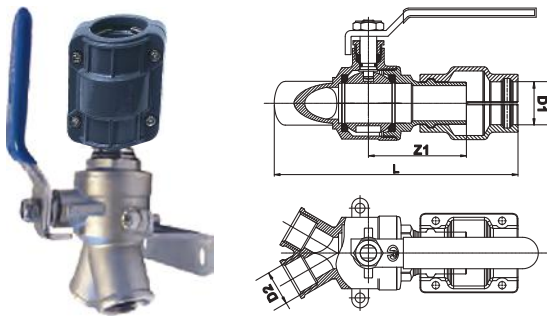

Double Port Female Ball Valve

Part Code	D1	D2	L
DV 20 21 01	20	½"	133
DV 25 21 01	25	½"	144



Flanged Butterfly Valve

Part Code	Nominal Diameter	Length	MOC
FV 67 CI 02	65	188	Cast Iron
FV 67 SS 02	65	188	Stainless Steel
FV 84 CI 01	80	210	Cast Iron
FV 84 SS 02	80	210	Stainless Steel
FV A1 CI 02	100	236	Cast Iron
FV A1 SS 02	100	236	Stainless Steel
FV A2 CI 02	150	256	Cast Iron
FV A2 SS 02	150	256	Stainless Steel
FV A3 CI 02	200	276	Cast Iron
FV A3 SS 02	200	276	Stainless Steel



Brass Ball Valve

Part Code	Size	Type
BV 21 FF 02	½"	Female
BV 21 MF 02	½"	Male/Female
BV 27 FF 02	¾"	Female
BV 34 FF 02	1"	Female
BV 42 FF 02	1-¼"	Female
BV 49 FF 02	1-½"	Female
BV 48 FF 02	2"	Female

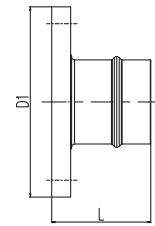
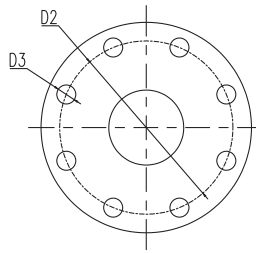

Aluminium Flange Connector

Part Code	Nominal Diameter	Flange Size	Bolt Size	L	D1	D2	D3
EF 67 00 01	65	65	M16	85	185	145	18
EF 84 00 01	80	80	M16	82	200	160	18
EF A1 00 01	100	100	M16	92	220	180	18
EF A2 00 01	150	150	M20	100	285	240	22
EF A3 00 01	200	200	M20	109	340	295	22

Note: Corresponding bolts & gasket would be supplied along with flange.



Threaded Flange Stainless/ Carbon Steel

Dimensions conforms to F – Class standard

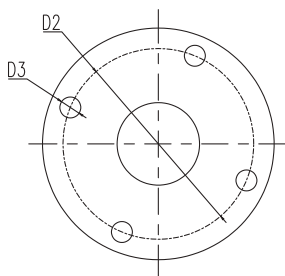

Part Code	Nominal Diameter	Thread Size	Bolt Size	D1	D2	D3	Thickness
TF 25 34 SS	25	1"	M12	120	87	18	28
TF 40 49 SS	40	1-½"	M16	140	105	18	32
TF 50 48 SS	50	2"	M16	165	127	18	34
TF 67 48 SS	65	2"	M16	185	146	18	32
TF 67 47 SS	65	2-½"	M16	185	145	18	32
TF 84 47 SS	80	2-½"	M16	205	165	18	34
TF 84 46 SS	80	3"	M16	205	165	18	34
TF A1 46 SS	100	3"	M16	230	191	18	40
TF 25 34 CS	25	1"	M16	120	87	18	28
TF 40 49 CS	40	1-½"	M16	140	105	18	32
TF 50 48 CS	50	2"	M16	165	127	18	34
TF 67 48 CS	65	2"	M16	185	146	18	32
TF 67 47 CS	65	2-½"	M16	185	145	18	32
TF 84 47 CS	80	2-½"	M16	205	165	18	34
TF 84 46 CS	80	3"	M16	205	165	18	34
TF A1 46 CS	100	3"	M16	230	191	18	40

Note: Corresponding bolts & gasket would be supplied along with flange.

4 & 8 nos. of bolts supplied along with the flanges from 25 to 63 mm & 80 to 110mm respectively.

Mounting & Installation Accessories

Features

- Easy to adapt to various pipeline structures;
- Suspension, vertical and horizontal mounting on walls, beams, trunking, etc.
- Offers high degree of rigidity
- Load carrying capacity tested at 120 kg (vertical load)
- Tested for 72 hours salt water bath test conformed to ASTM B117, IS:1608



Metallic Fixing Clamp

Part Code	Suitable Size	Connection
FC 20 00 00	20	M8
FC 25 00 00	25	M8
FC 40 00 00	40	M8
FC 50 00 00	50	M8
FC 67 00 00	65	M8
FC 84 00 00	80	M8
FC A1 00 00	100	M8
FC A2 00 00	150	M8
FC A2 00 UU	200	M8

Cantilever Mounting Bracket

Part Code	L	I	Suitable Size
MB 03 00 MS	300	32	20–200
MB 05 00 MS	500	32	20–200
MB 08 00 MS	800	32	20–200
MB 12 00 MS	1200	32	20–200



Girder/Beam Clamp

Part Code	Size	Length
GC 36 M8 MS	M8	36

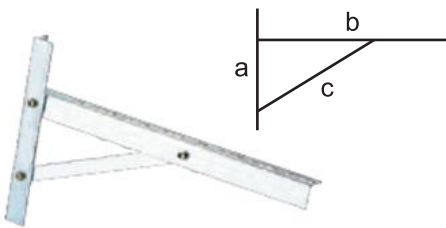

Triangular Mounting Bracket

Part Code	A	B	C
TB 05 00 MS	300	500	312

Allen Bolts



Part Code	D	L
AB 50 M8 MS	M8	50
AB 60 M8 MS	M8	60
AB 70 M8 MS	M8	70



Threaded Rod

Part Code	D	L	Remarks
TR 30 M8 MS	M8	3000	Threaded Rod
CB 40 M8 MS	M8	40	Connecting Buckle



Pipe Cutter

Part Code	Description	Suitable Size
PC 67 20 00	Pipe Cutter	20–67mm
PC A1 40 00	Pipe Cutter	40–110mm



Hole Deburring tool

Part Code	Description	Suitable Size
HD 16 00 00	Hole Deburer	20–205



Hole Saw Cutter

Part Code	D	L	Suitable Size
HC 14 00 00	14	50	DN25
HC 19 00 00	19	50	DN40–DN200
HC 25 00 00	25	50	DN65–DN200
HC 38 00 00	38	50	DN100–DN200
HC 51 00 00	51	50	DN100–DN200



Glycerine filled Pressure Gauge

Part Code	Dial Size	Connection
PG A1 21 00	4"	½" Male
PG A2 21 00	6"	½" Male

Feature of Pressure Gauge:

- Standard conformed : EN837–1
- Calibration certificate with every Gauge
- Body Material : SS304
- Specified Accuracy : ±1% FSD
- Overload Protection : 130% of SPAN



Pipe Deburring tool

Part Code	Description	Suitable Size
PD 50 20 00	Pipe Deburer	DN20–DN50



Drill Holder

Part Code	Description	Suitable Size
DH 14 30 00	Drill Holder	DN25
DH 32 A2 00	Drill Holder	DN25–DN200



Pipe Marker

Part Code	Suitable Size
PM A1 25 00	DN25–DN100

Sizing Calculator



Flow CFM	Length in Metre									
	50m	100m	150m	300m	500m	750m	1000m	1300m	1600m	2000m
6	20	20	20	20	20	20	20	25	25	25
18	20	20	20	25	25	25	25	25	25	40
30	20	25	25	25	25	25	40	40	40	40
42	25	25	25	25	40	40	40	40	40	40
60	25	25	25	40	40	40	40	40	40	50
88	25	40	40	40	40	40	40	50	50	50
145	40	40	40	40	50	50	50	50	50	50
205	40	40	40	50	50	50	67	67	67	67
300	40	40	50	50	67	67	67	67	67	67
445	40	50	50	50	67	67	67	84	84	84
590	50	50	67	67	67	84	84	101	101	101
735	50	50	67	67	67	101	101	101	101	101
880	50	67	67	84	84	101	101	101	101	101
1030	67	67	80	84	84	101	101	101	101	153
1175	67	84	84	84	101	101	101	101	153	153
1470	67	84	84	84	101	101	101	153	153	153
1760	84	84	84	101	101	153	153	153	153	153
2050	84	84	101	101	153	153	153	153	153	153
2355	84	101	101	101	153	153	153	153	153	153
2650	84	101	101	153	153	153	153	153	153	153
2940	84	101	101	153	153	153	153	153	153	153
3235	101	101	101	153	153	153	153	153	153	153
3530	101	101	153	153	153	153	153	153	153	153
3825	153	153	153	153	153	153	153	153	153	205
4240	153	153	153	153	153	153	153	205	205	205
4710	205	205	205	205	205	205	205	205	205	205
5000	205	205	205	205	205	205	205	205	205	205
5890	205	205	205	205	205	205	205	205	205	205
7065	205	205	205	205	205	205	205	205	205	205

In addition to total pipe length calculated, we need to consider the equivalent length of following valves/connectors to correctly select diameter of piping network.

Type of Fittings						
Pipe Size	Elbow	Tee	Branch Tee	Ball/Butterfly valve	Check valve	Reducing Connector
20	0.25	0.35	1.2	0.2	1.5	0.35
25	0.4	0.5	1.5	0.3	2	0.5
40	0.6	0.8	2.4	0.5	3.2	0.7
50	0.8	1	3	0.6	4	1
67	1	1.3	4	0.8	5.2	1.5
84	1.3	1.6	4.8	1	6.4	2
101	1.6	2	6	1.3	8	2.5
153	2.4	3	9	1.9	12	3.6
205	3.2	4	12	2.6	16	4.8

Calculated at 8 bar pressure considering closed loop system.



Tool Kit

Item Name	Specification	Qty.
Tool Kit	460 x530mm	1
Marker	DN20–50	1
Hole Deburrer	DN20–200	1
Pipe Cutter	Ø6–67	1
Hole Saw Cutter	Ø14	1
Hole Saw Cutter	Ø19	1
Hole Saw Cutter	Ø25	1
Allen Key	6mm	1
Allen Key	8mm	1
Allen Key	3mm	1
Drill Holder	DN25–205	1



Sample Kit

Part Code	H	L	I
SK 84 25 00	200	270	190



Lugging Machines

Part Code	Operation	Suitable Size
ML A3 67 00	Manual	67–205
BL A3 67 00	Battery	67–205



Cordless Driver Kit

Part Code	Battery	Torque
CD A3 20 00	12 V	110Nm



ShiftAir® hereby declares that it agrees to replace or repair free of cost components which do not perform owing to manufacturing or material defect within 10 years from the date of installation.

The present guarantee is valid provided:

ShiftAir engineers have proper accessibility to examine the products with issue.
Materials must operate within the specific / recommend range of working conditions

The guarantee becomes automatically null & void if:

If it puts into operations beyond recommended technical parameters
Defects being occurred because of mishandling
Defects caused by product modifications which is not approved by ShiftAir in advance

ShiftAir has a policy of continually develop products and therefore reserves the right to modify any product shown in this catalogue

Certifications



We meet the following standards:





ShiftAir Pneumatics (Unit-II)

Plot No.-D1, Sector-23, 23-24 Main Road, Faridabad- 121005, Haryana, India

Phone: 0129- 4177575, **Email:** sales@shiftairindia.com, customer.support@shiftairindia.com

Website: www.shiftairindia.com